

FIG. 1

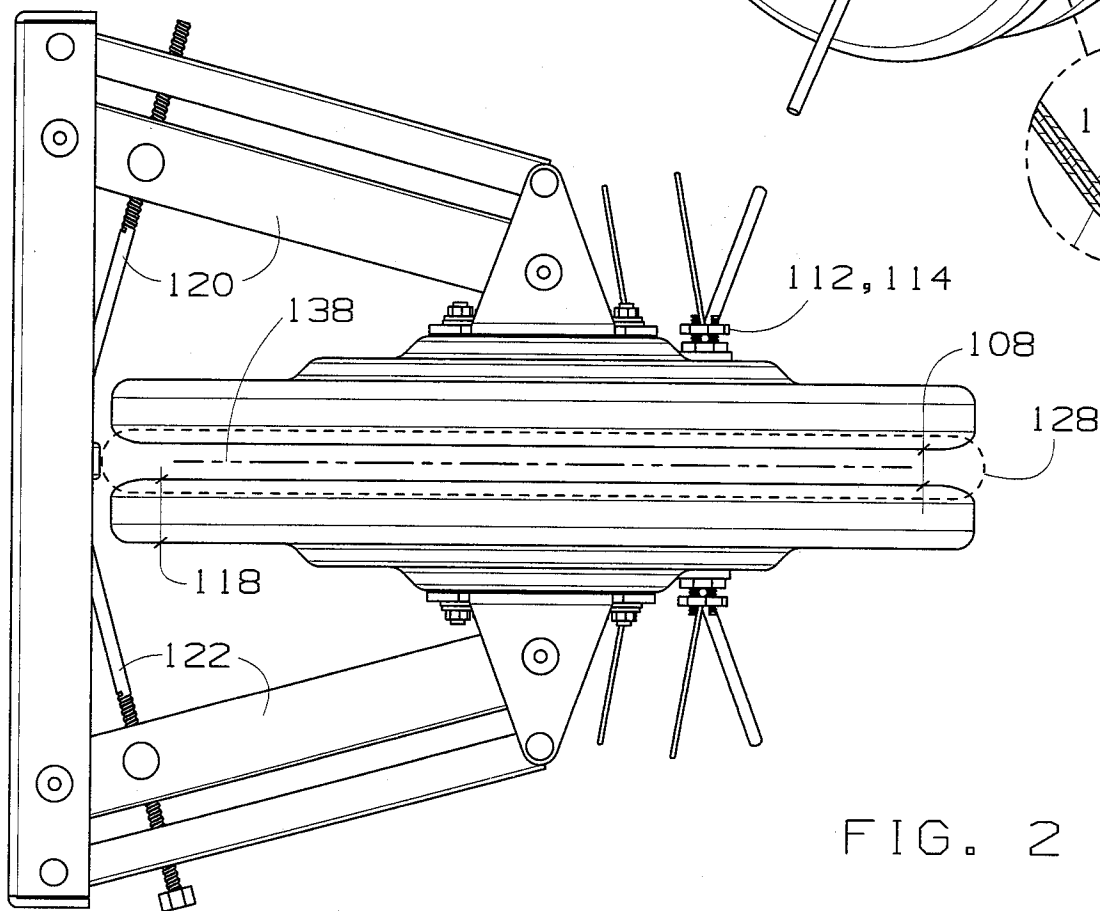

FIG. 2



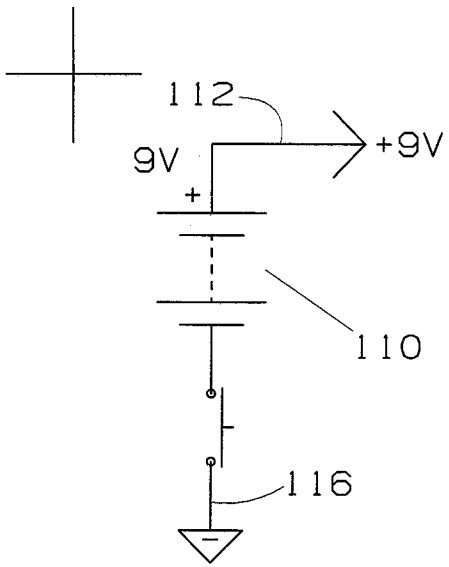

FIG. 3A
PRIOR ART

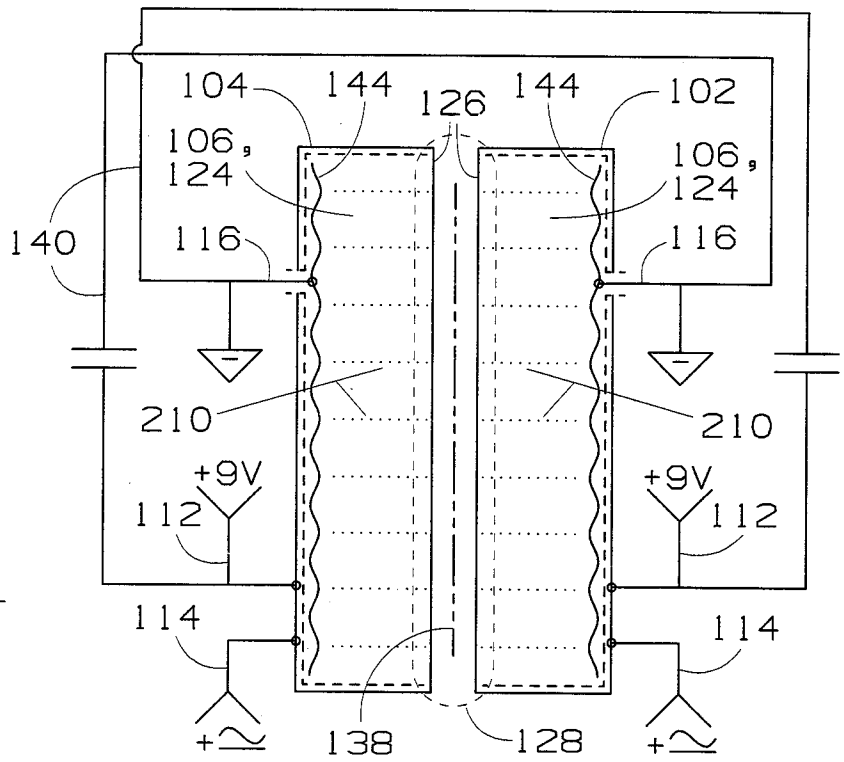

FIG. 3

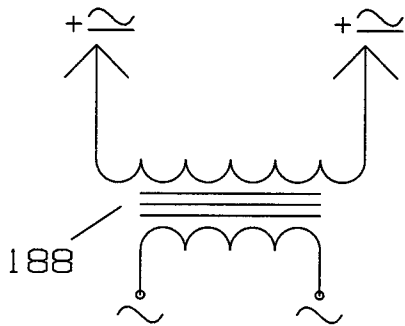

FIG. 4A
PRIOR ART

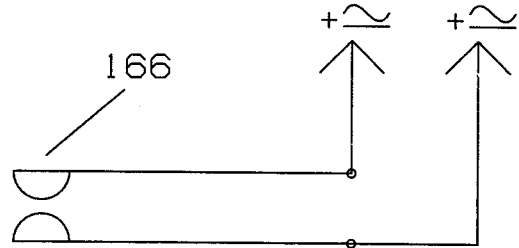

FIG. 4

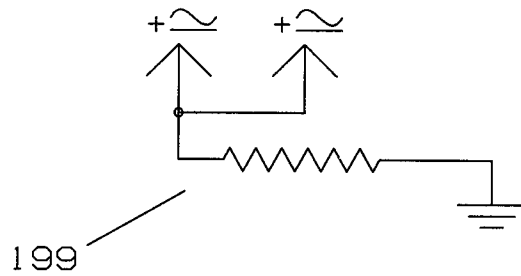
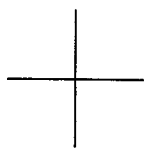

FIG. 5
PRIOR ART



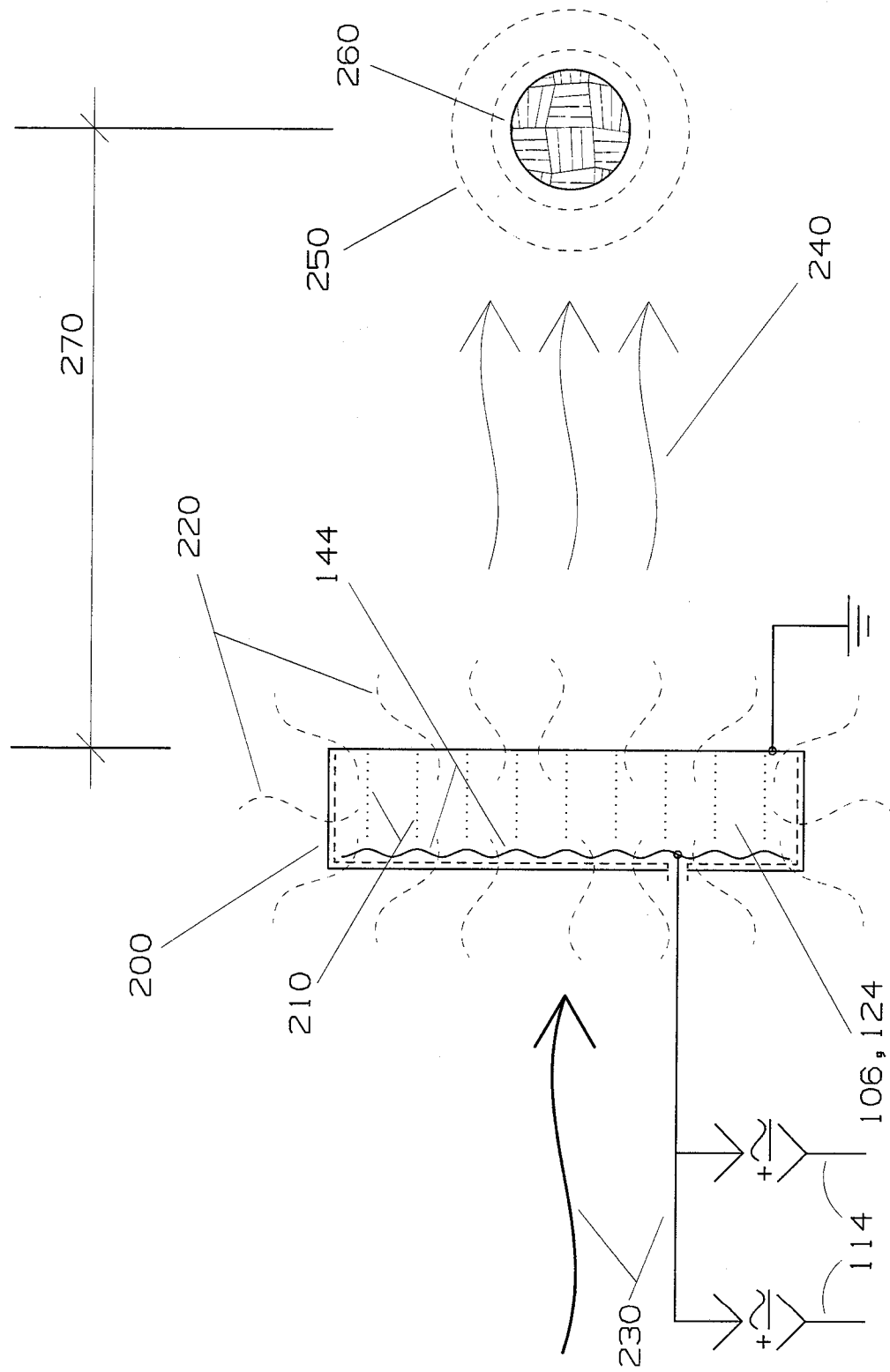
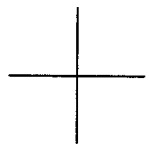

FIG. 6A



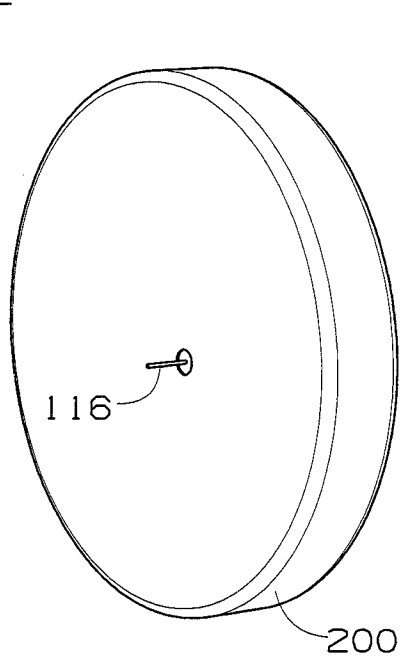
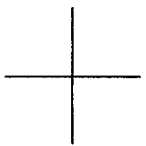

FIG. 6

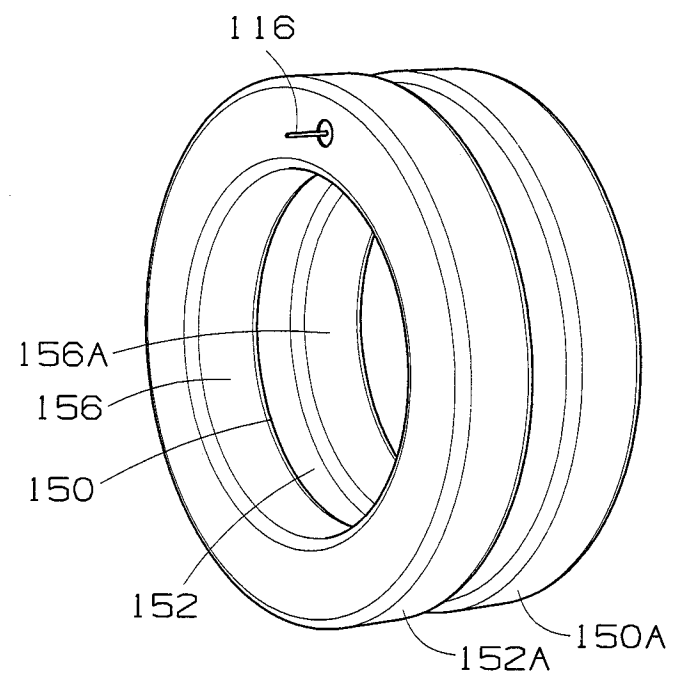

FIG. 7

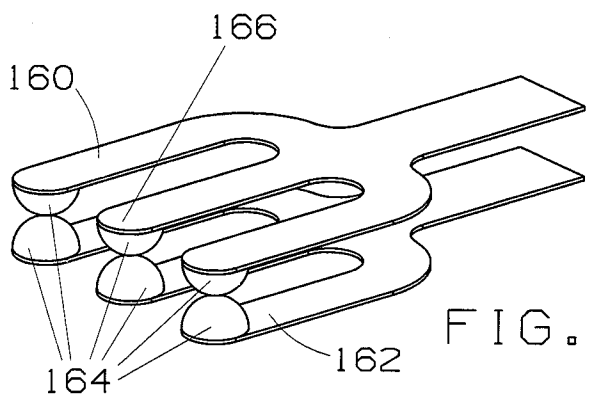

FIG. 8

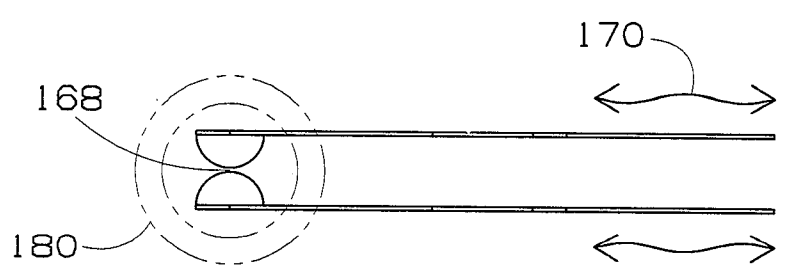
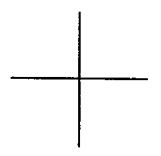

FIG. 9



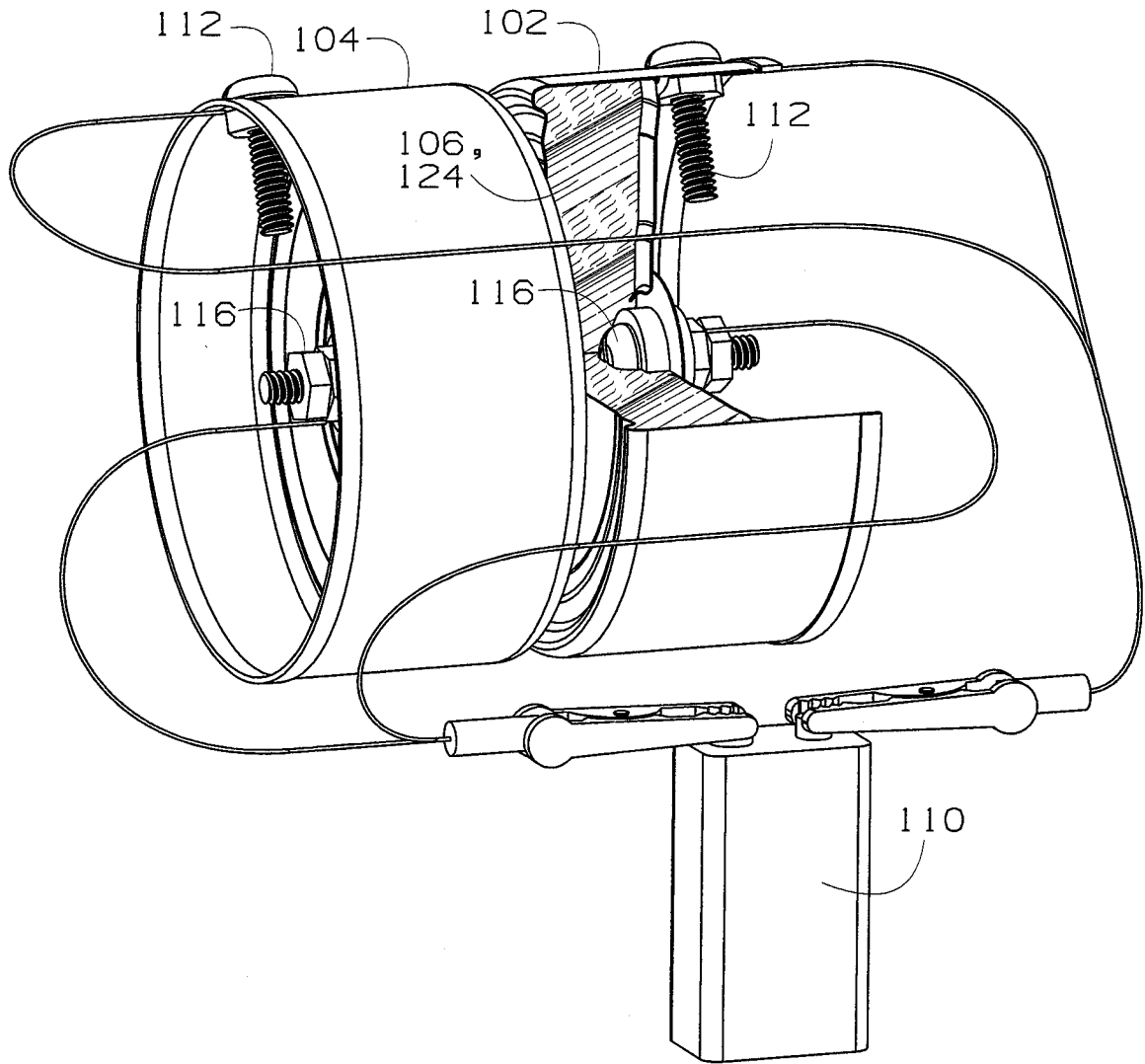
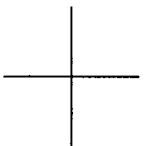
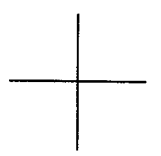

FIG. 10



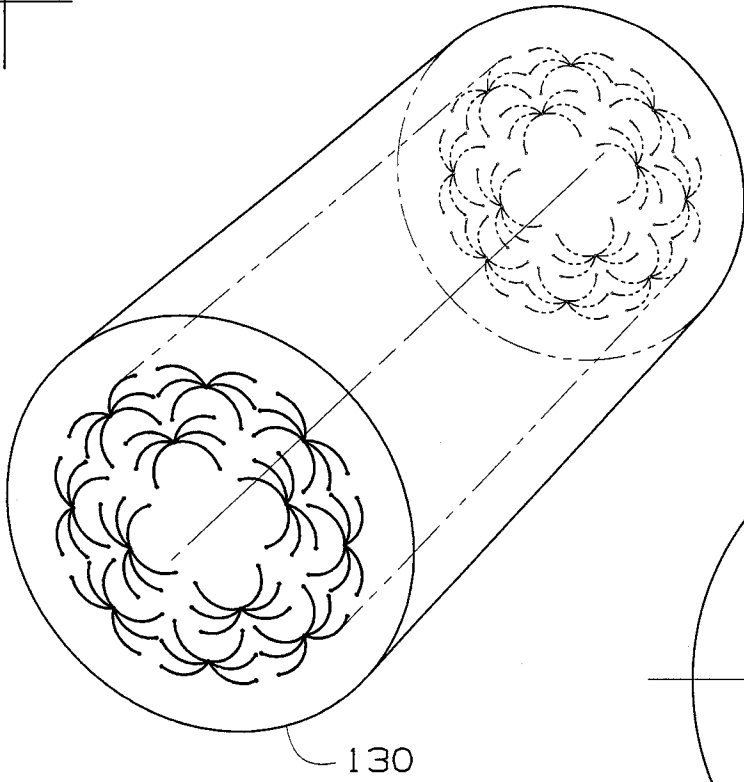
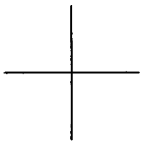

FIG. 11A

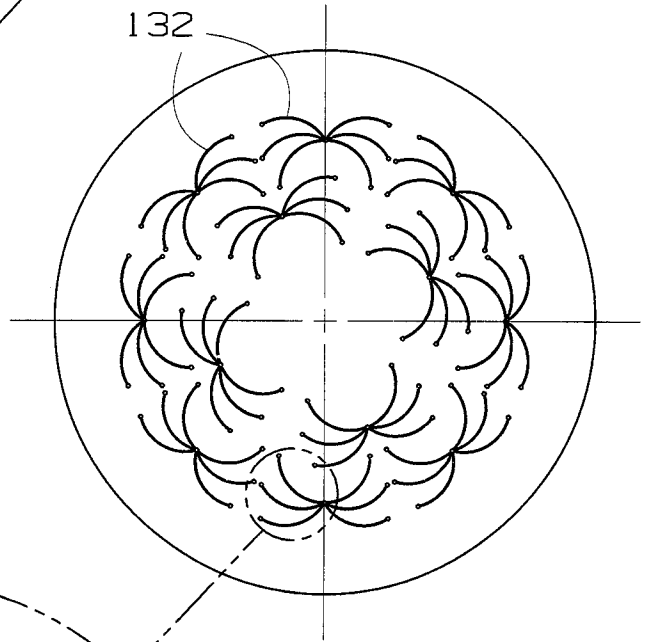

FIG. 11B

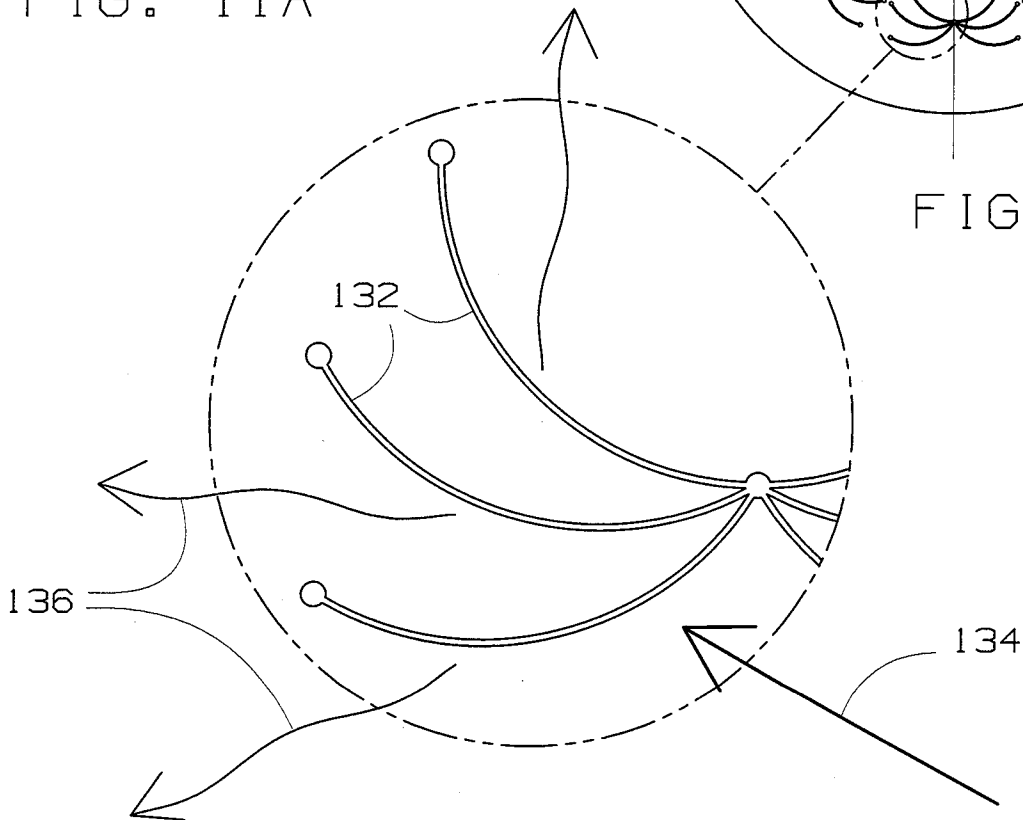
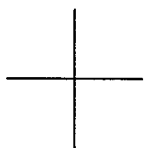

FIG. 11C



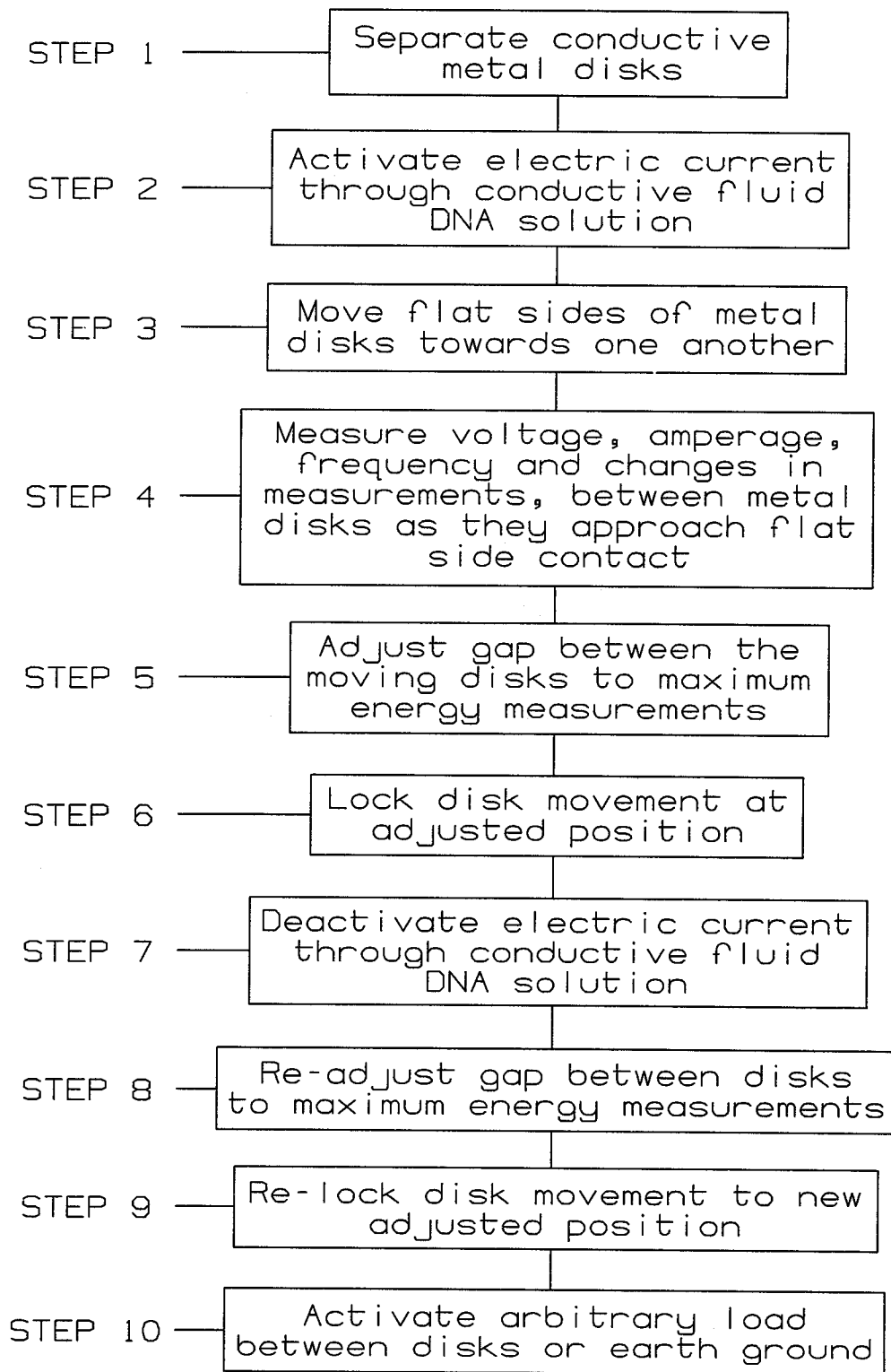

FIG. 12

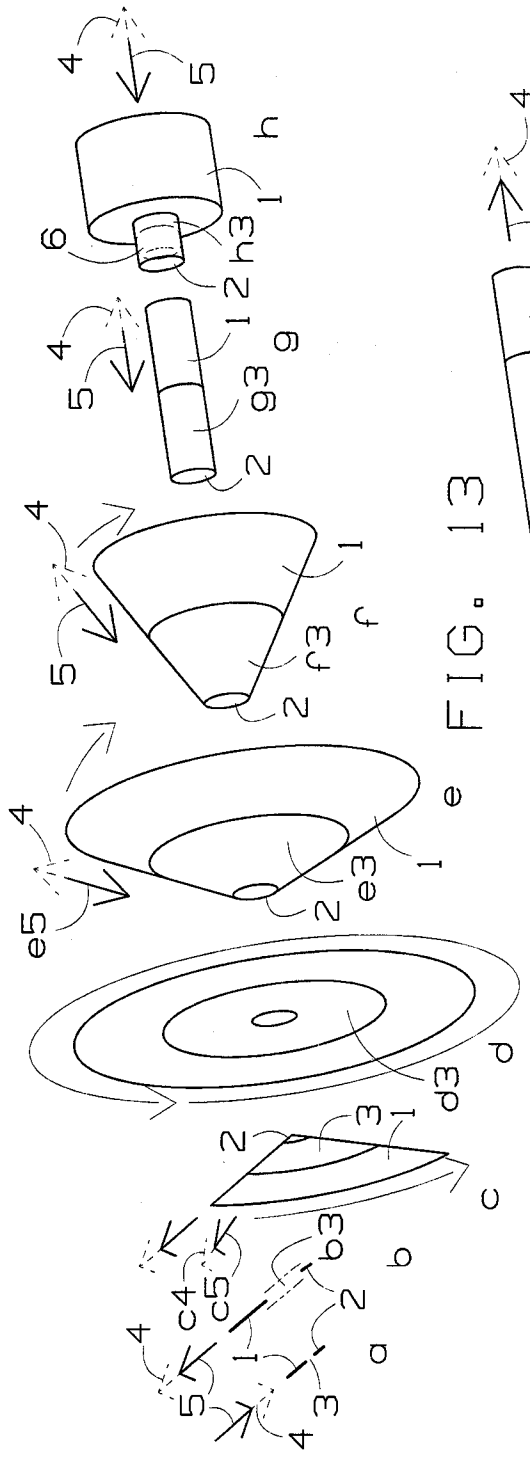
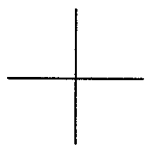

FIG. 13

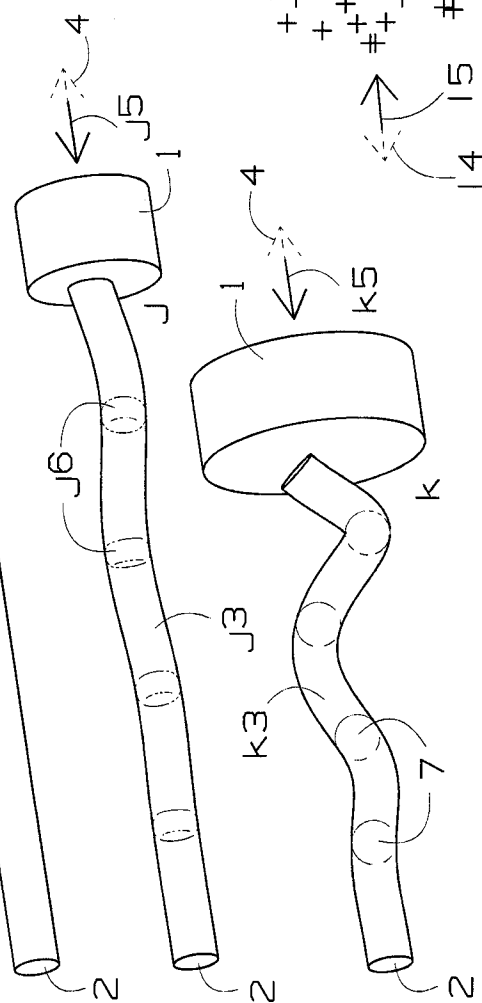
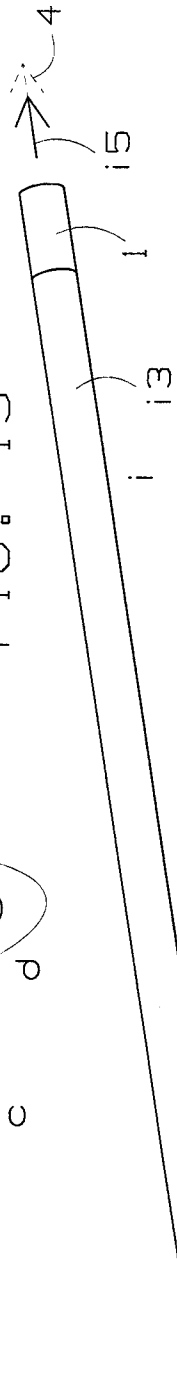

FIG. 14

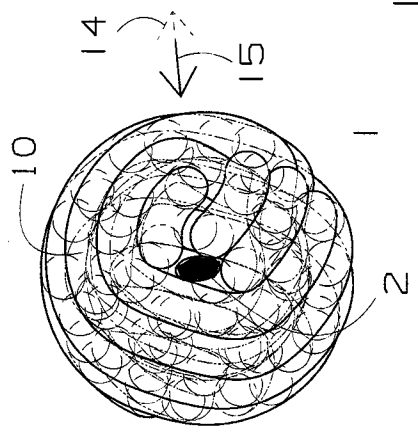
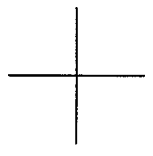

FIG. 15



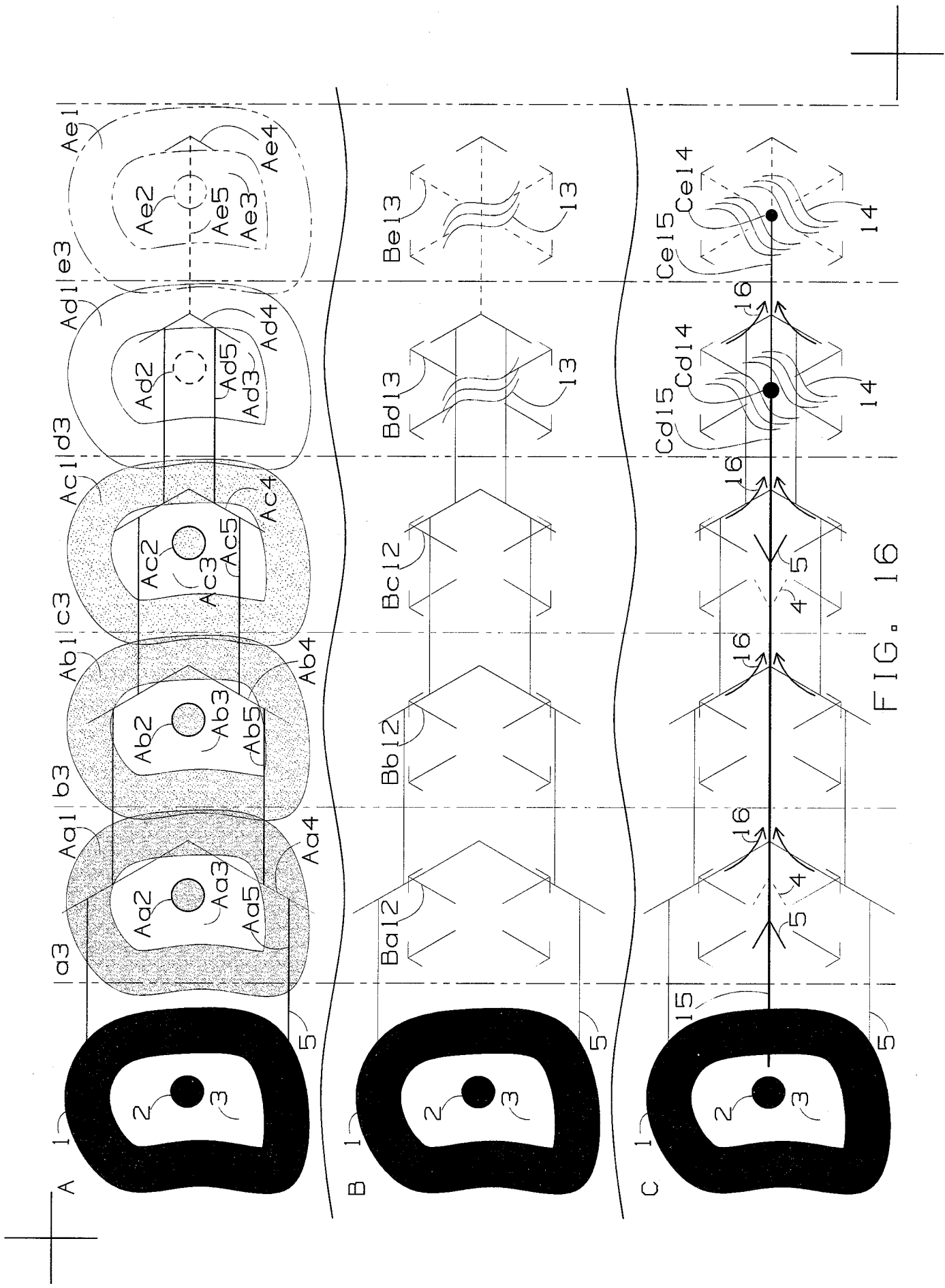

FIG. 16